



FLOOR MODEL LAUNDRY TUB SM-19-FX

FLOOR MODEL LAUNDRY TUB

FEATURES:

- Single compartment, multi-purpose sink manufactured from an innovative foam process. The polypropylene structural composite sink utilizes this unique molding process, producing seamless corners and edges while providing unrivaled strength. Low-maintenance polyethylene legs offer structural rigidity.
- Convenient accessories include a bottle holder, drying rack, front and side towel holders, p-trap and supplies. (models SM-19-FA & SM-19-FC only)
- Leak-proof, integral molded-in drain with stopper.
- Unique Pull-out faucet offers two different sprays and wing handles for easy shut off even with soapy hands. (model SM-19-FC only)
- Large, self-draining back shelf with retainer curb that prohibits water run-off except into tub.
- Easy to assemble and install.

APPLICABLE CODES & STANDARDS:

- IAPMO®
- #B45.0 and #B45.5; Drain - #B125
- ANSI – Specification Z 124-2011



SM-19-FC model shown

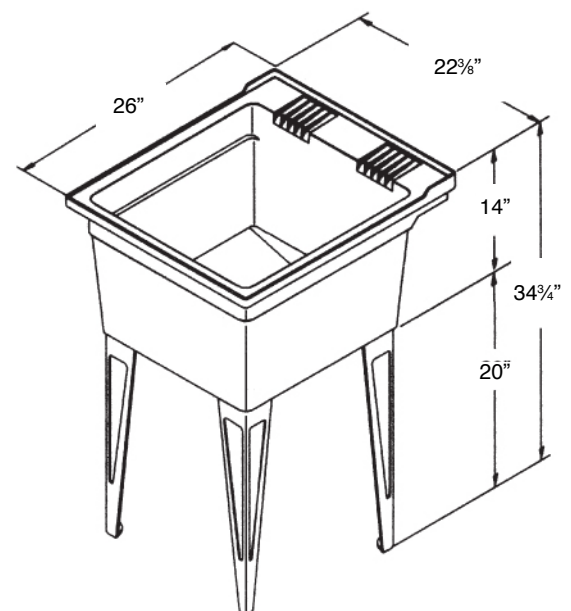
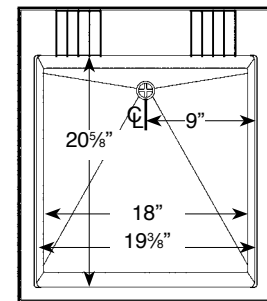

	MODEL NO.	DESCRIPTION	Width	Depth	Height
LAUNDRY TUB (only)					
<input type="checkbox"/>	SM-19-F	Tub Only	22 ³ / ₈ "	26"	34 ³ / ₄ "
TUB KIT (less faucet)					
<input type="checkbox"/>	SM-19-FA	Tub and Accessories	22 ³ / ₈ "	26"	34 ³ / ₄ "
COMPLETE TUB KIT (with faucet)					
<input type="checkbox"/>	SM-19-FC	Tub, Faucet & Accessories	22 ³ / ₈ "	26"	34 ³ / ₄ "
INDIVIDUAL COMPONENTS					
<input type="checkbox"/>	SM-LT-TL	Plastic Leg			
<input type="checkbox"/>	SM-LT-AP	Accessery Kit			
<input type="checkbox"/>	SM-LT-WF	Wall Filler Kit			
<input type="checkbox"/>	PSLTF-4	Pull-out Faucet			